

HEAVY DUTY COLLISION REPAIR

Including frame measurement, high-reach pulling and induction heating

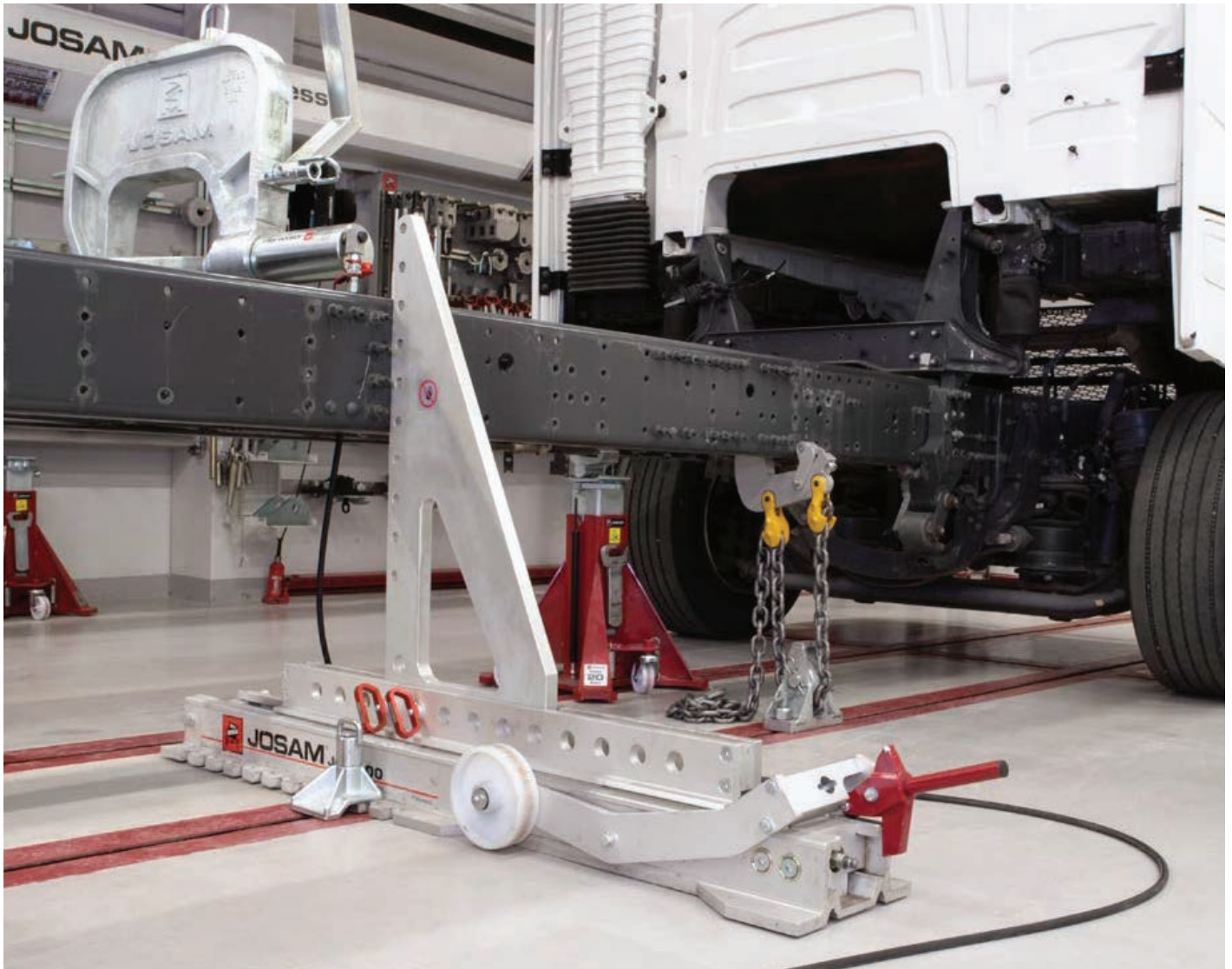



Collision repair catalogue

General information..... Page 3

System comparison Page 3

Floor beam solution Page 4

Floor anchoring expander solution Page 5

JOSAM frame press..... Page 6

Premium frame straightening kit Page 6

Advanced frame straightening kit..... Page 11

Basic frame straightening kit Page 15

Options Page 19

Accessories Page 26

JOSAM i-press Page 29

Advanced frame straightening kit..... Page 29

Options Page 36

Accessories Page 41



EQUIPMENT SUITED FOR TRUCKS



EQUIPMENT SUITED FOR CABS



EQUIPMENT SUITED FOR BUSES AND ARTICULATED BUSES



EQUIPMENT SUITED FOR FULL TRAILERS



EQUIPMENT SUITED FOR SEMI-TRAILERS



EQUIPMENT SUITED FOR MINI-BUSES

System comparison

JOSAM frame press

JOSAM frame press is a 20-ton frame straightening solution used with a fixed floor frame. It is the natural choice when building a new workshop or installing in a workshop which has already an I-beam floor frame installed.

Trolleys can be moved stepless along the chassis and are locked with two anchoring holders. Different brackets allow to change height and width easily.

The active trolley can both press and pull. Good possibilities to straighten (semi-)trailers.

This system is made to expand both in efficiency and flexibility. By complementing the frame press system with a JO series high reach pulling tower, cabs and buses can also be straightened.



JOSAM i-press

A 10-ton frame straightening solution suitable for complementing a workshop with straightening capabilities, when there is no I-beam floor frame installed.

Since the floor frame is not casted into the floor it can be easily removed and installed in another premises simply by drilling new holes.

The trolleys can only be used for pressing. Straightening (semi-)trailers is possible to a limited degree. By complementing the i-press system with a CT series high reach pulling tower, cabs and buses can also be straightened.



Frame and cab straightening with the JOSAM floor beam solution

To be able to use **JOSAM frame press** and straightening equipment as well as **JO-series high reach pulling towers**, the workshop needs floor beams installed to transfer the required force onto the object/vehicle.

The floor beams are to be casted in the workshop floor. This gives the advantages of a flexible work area, easy to get the vehicle onto the workplace, as well as level floor and ergonomic work heights. A local construction company normally handles the production and installation of such floor beams. It saves both time and money.

Please contact your local Josam representative to plan your work area and receive appropriate drawings.

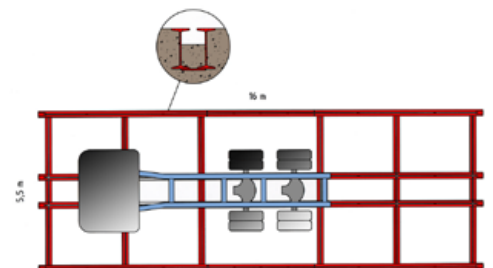
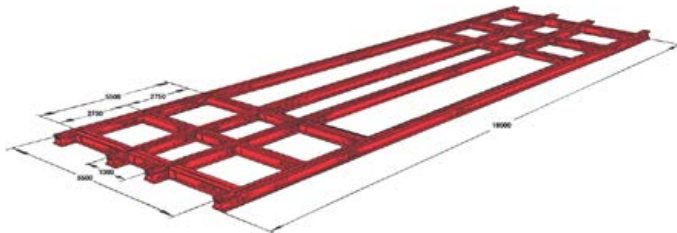

Frame straightening and high-reach pulling with floor beams

The drawings JO117 and JO116 are recommendations for a floor beam layout.

- **JO117** is used when the work bay width exceeds 6.5 metres.
- **JO116** is used when the work bay width is 6.5 metres or less.

Both layouts allow frame straightening, cab straightening as well as high reach pulling on buses and high bodywork.

The length of the structure can easily be adapted to the actual workshop by shortening the structure at the middle section. The K1 and K3 drawings are essential for the perspective view of the floor beams.

Straightening pit

If the workshop is considering a straightening pit, Josam will provide the **JO2036** drawing. Please note that a straightening pit cannot be used for cab straightening.

The **K1**, **K2** and **K3** drawings are perspective drawings of the above solutions.

Regarding the quality of the concrete normal local specifications for a truck workshop floor are adequate. Pour the concrete with care and make sure it is in level with the floor beams! Also, it is important to consider drainage of the floor beams.

Check the JOSAM website for details, www.josam.se.



Frame straightening with floor anchoring expander solution and a centre beam



If the workshop would like to do frame straightening by using the floor anchoring expander solution **JOSAM i-press** with a centre beam then the following drawing is available:

- **JO300010**

The centre beam with floor anchoring expanders must be purchased from JOSAM in sections of 3.2 metres. This allows the customer to decide the length of the straightening area. Concrete and reinforcements according to drawing JO300010.

High-reach pulling with floor anchoring

If the workshop is planning to also perform high-reach pulling, we recommend a floor anchoring expander solution, **CT-series cab tower**. For this purpose the following drawings are available:

- **JO2324-B** is used for cab straightening directly on the chassis and for bus repair.

Floor anchoring expanders must be purchased from JOSAM. Concrete and reinforcements according to drawing JO2324-B.

For further inquiries regarding construction JOSAM recommends that the workshop consult a local construction engineer. For layout inquiries we recommend that the workshop contacts the local JOSAM dealer. The core drill itself as well as the fastening tool can be purchased from JOSAM.





Frame press – Premium kit

Choose this set when frame straightening is to be performed full time in a dedicated bay.

This straightening set covers the demanding needs to correct a truck chassis. The set can of course be upgraded to increase efficiency and functionality to be able to also straighten (semi-) trailers, cabs and buses.

The set consists of:

- **Three 20 ton press/pull trolleys** with a full set of brackets, all in high strength aluminum. This allows for both press and pull operations to perform side sway correction.
- **Two vertical presses** that together with the anchoring kit enable you to correct vertical bends and chassis twist. Additionally, **a flex foot kit** is included, highly useful when working in a confined space.
- **Three C-clamp kits** (40, 20 and 10 ton) as well as **two hydraulic kits** (20 and 10 ton), which are used to correct local deformations.
- **A remote controlled hydraulic pump** with 4 outlets, as well as a **foot operated pump**, to maneuver multiple hydraulic units at the same time.

For options and accessories, see pages 19–28.

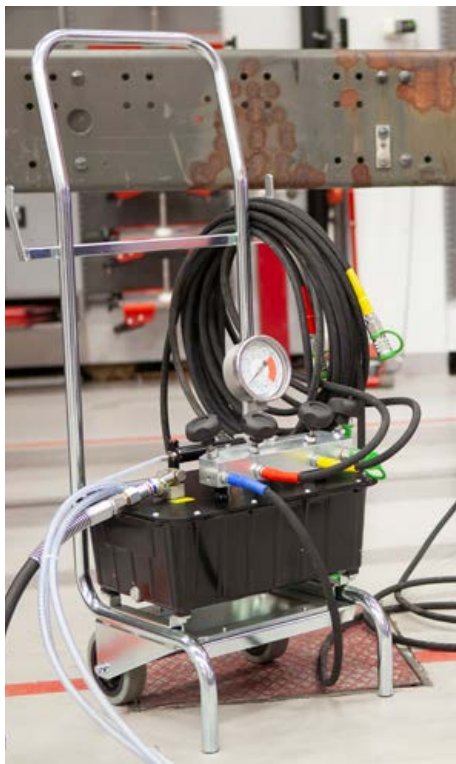



JO FP PREMIUM K/15910

Premium frame straightening kit excluding floor beams

Exklusiv ramriktssats exklusive golvspår

Exklusiv Rahmenrichtsatz exklusive Fundamentrahmen



Premium kit

#	Article #	Order #	Pcs.	EN	SE	DE
1	JO 20 AL	11109	3	Press/pull trolley 20 ton aluminium	Press/dragbrygga 20 ton aluminium	Press/Zugbrücke 20 Tonnen Aluminium
2	JO HA 20	15076	1	20 ton hydraulic kit	20 ton hydrauliktillbehörssats	20 Tonnen Zubehörsatz Hydraulik

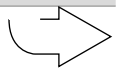
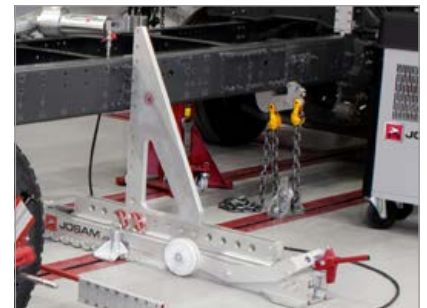
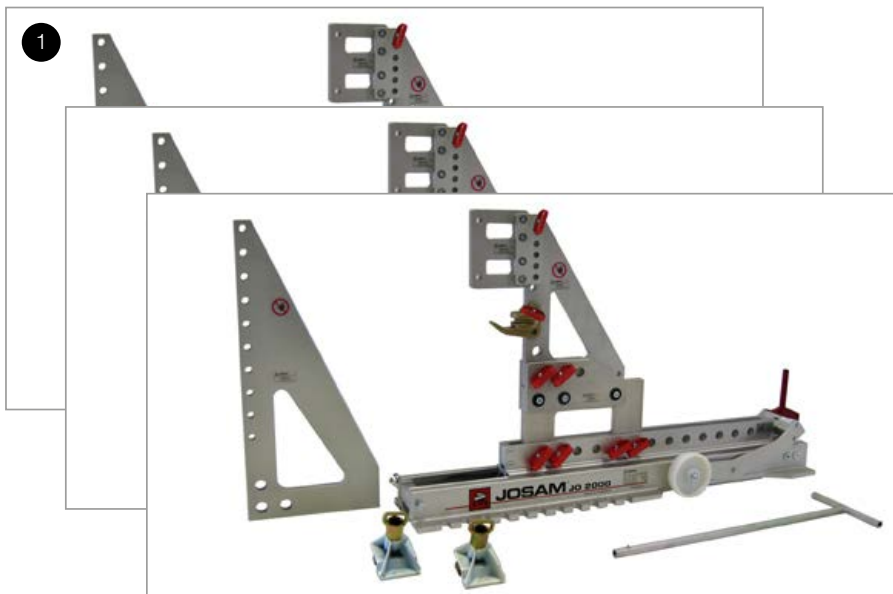

Table continues on next page
Tabellen fortsätter på nästa sida
Tabelle weiter auf der nächsten Seite



The JOSAM frame press is anchored to a frame rack in the floor.

These rails are not included, but drawings for local construction are provided.

JOSAM frame press förankras i golvspår ingjutna i verkstadsgolvet.

Dessa golvspår ingår ej, men ritningar för lokal konstruktion finns tillgängliga.

Die JOSAM-Rahmenrichtanlage ist an einem Fundamentrahmen im Boden verankert. Diese Schienen sind nicht enthalten, aber Zeichnungen für den lokalen Aufbau werden zur Verfügung gestellt.



3	JO HA 10	15077	1	10 ton hydraulic kit	10 ton hydraulikillbehörssats	10 Tonnen Zubehörsatz Hydraulik
4	SR 29 K	13495	1	10 ton C-clamp set with flat nose C-clamp	10 ton riktbygelsats med plattnosbygel	10 Tonnen Richtbügelsatz mit Bügel flachen Gegenlager
5	JO 1320 K	12590	1	20 ton C-clamp set	20 ton riktbygelsats	20 Tonnen Richtbügelsatz

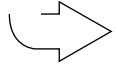

Table continues on next page
 Tabellen fortsätter på nästa sida
 Tabelle weiter auf der nächsten Seite





6	SR 450 N R	12585	1	40 ton C-clamp set for riveting and straightening	40 ton bygelsats för nitning och riktning	40 Tonnen Bügelsatz für Nieten und Richten
7	JO 1876 K	11108	1	20 ton straightening set frame	20 ton riktsets för ramfläns	20 Tonnen Richtsatz Rahmenflansch
8	SR 90 K	12587	1	Mounting display board, three sections	Upphängningstavla, tre sektioner	Montagewand, drei Sektionen

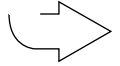
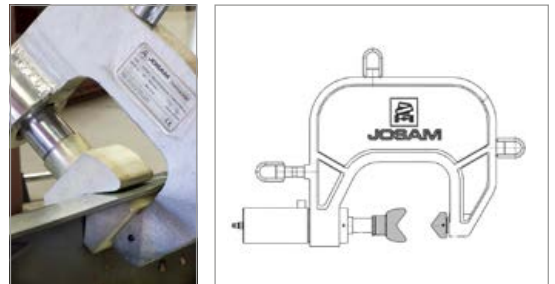
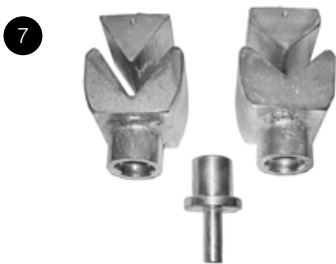
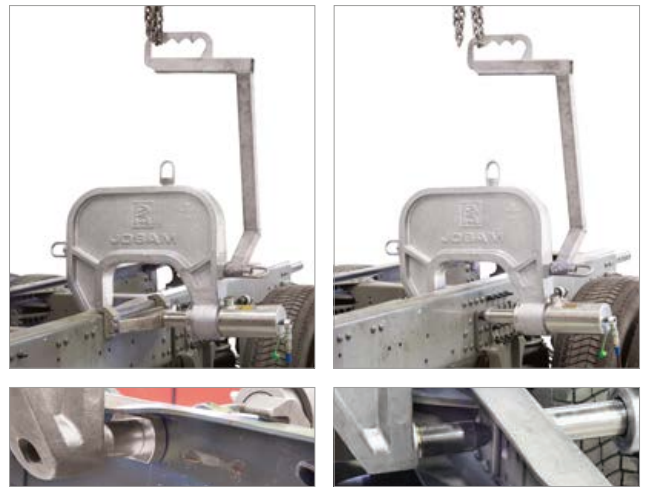
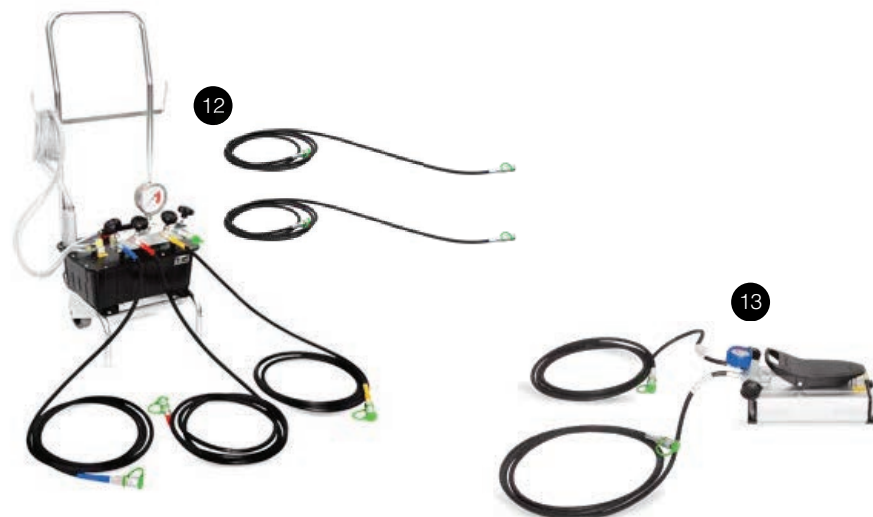
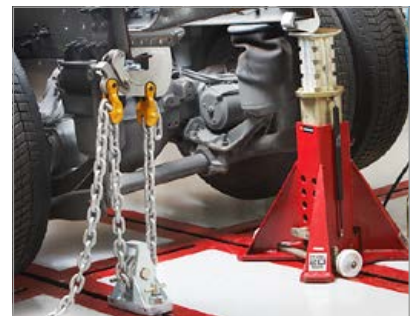
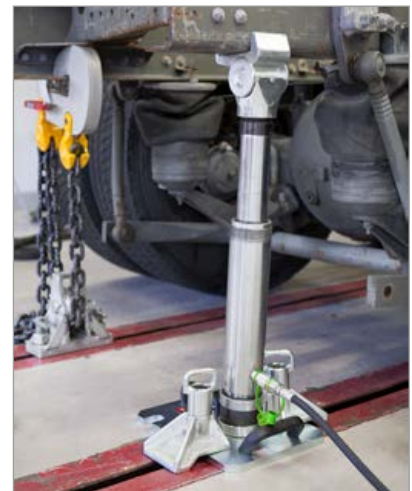

Table continues on next page
 Tabellen fortsätter på nästa sida
 Tabelle weiter auf der nächsten Seite





9	JO2513	15463	1	20 ton hydraulic cylinder with flex foot	20 ton hydraulisk cylinder med flexfot	20 Tonnen Hydraulikzylinder mit Flexfuss
10	JO2480 A	15818	2	Vertical press 20 ton with cylinder and frame-flange press heads	Vertikalpress 20 ton med cylinder och flänsstöd	Vertikalpresse 20 Tonnen mit Zylinder und Druckstücken
11	JO SA 3	15817	1	Straightening accessories basic set	Riktillbehör grundsats	Richten-Zubehör Grundausrüstung
12	H1039	14953	1	Remote controlled, air driven hydraulic pump with 4 outlets and two 6 m extension hoses	Fjärrmanövrerad lufthydraulisk pump med 4 utgångar och två 6-meters förlängningsslangar	Ferngesteuerte, lufthydraulische Pumpe mit 4 Ausgänge und zwei Stück 6 m Schläuche
13	H1053	16544	1	Foot controlled hydraulic pump with two 4 m hoses	Fotdriven hydraulisk pump med två 4-meters slangar	Fußgesteuerte, lufthydraulische Pumpe mit zwei 4 m Schläuche





Frame press – Advanced kit

Choose this set when frame straightening is to be performed part time in a dedicated bay.

This straightening set covers the normal needs to correct a truck chassis. The set can of course be upgraded to increase efficiency and functionality to be able to also straighten (semi-) trailers, cabs and buses.

The set consists of:

- **One 20 ton press/pull trolley and two 20 ton counterstay trolleys** with brackets, all in high strength aluminum. This allows for both press and pull operations to perform side sway correction.
- **Two vertical presses** that together with the anchoring kit enable you to correct vertical bends and chassis twist.
- **Two C-clamp kits** (40 and 10 ton) as well as **two hydraulic kits** (20 and 10 ton), which are used to correct local deformations.
- **A remote controlled hydraulic pump** with 4 outlets, to maneuver multiple hydraulic units at the same time.

For options and accessories, see pages 19–28.

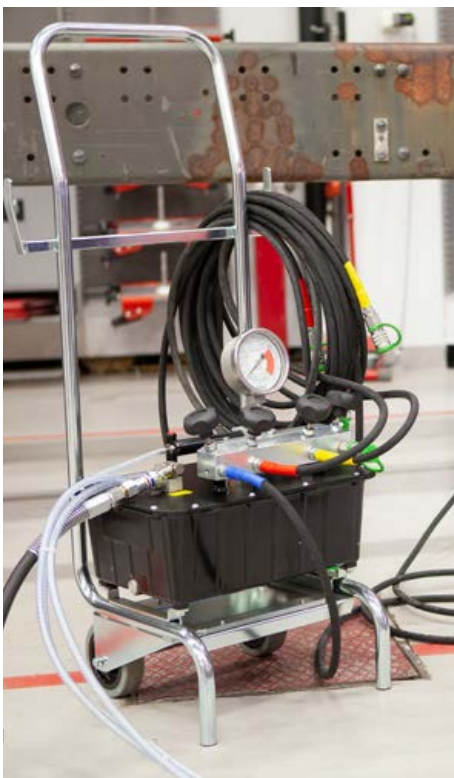



JO FP ADVANCED K/15909

Advanced frame straightening kit excluding floor beams

Avancerad ramriktssats exklusive golvspår

Fortgeschritten Rahmenrichtsatz exklusive Fundamentrahmen



Advanced kit

#	Article #	Order #	Pcs.	EN	SE	DE
1	JO 21 AL	11116	2	Counterstay trolley 20 ton aluminium	Mothållsbrygga 20 ton aluminium	Gegenbrücke 20 Tonnen Aluminium
2	JO 20 AL	11109	1	Press/pull trolley 20 ton aluminium	Press/dragbrygga 20 ton aluminium	Press/Zugbrücke 20 Tonnen Aluminium
3	JO HA 20	15076	1	20 ton hydraulic kit	20 ton hydraulikillbehörssats	20 Tonnen Zubehörsatz Hydraulik

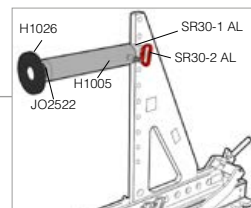

Table continues on next page
 Tabellen fortsätter på nästa sida
 Tabelle weiter auf der nächsten Seite

The JOSAM frame press is anchored to a frame rack in the floor.

These rails are not included, but drawings for local construction are provided.

JOSAM frame press förankras i golvspår ingjutna i verkstadsgolvet.

Dessa golvspår ingår ej, men ritningar för lokal konstruktion finns tillgängliga.

Die JOSAM-Rahmenrichtanlage ist an einem Fundamentrahmen im Boden verankert. Diese Schienen sind nicht enthalten, aber Zeichnungen für den lokalen Aufbau werden zur Verfügung gestellt.



4	JO HA 10	15077	1	10 ton hydraulic kit	10 ton hydrauliktillbehörssats	10 Tonnen Zubehörsatz Hydraulik
5	SR 31 K	12588	1	10 ton C-clamp set	10 ton riktbygelsats	10 Tonnen Richtbügelsatz
6	SR 450 N R	12585	1	40 ton C-clamp set for riveting and straightening	40 ton bygelsats för nitning och riktning	40 Tonnen Bügelsatz für Nieten und Richten

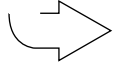
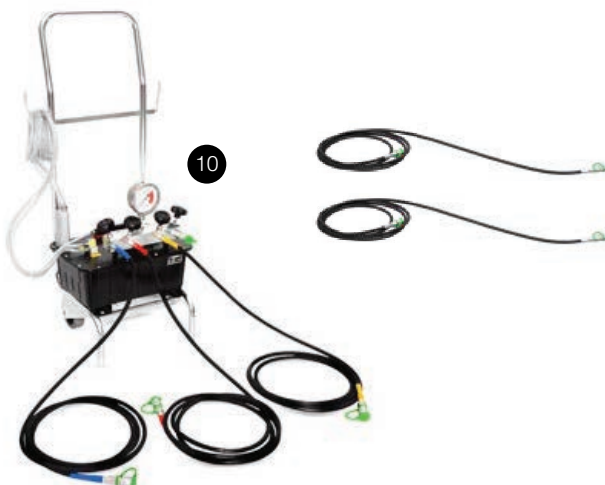
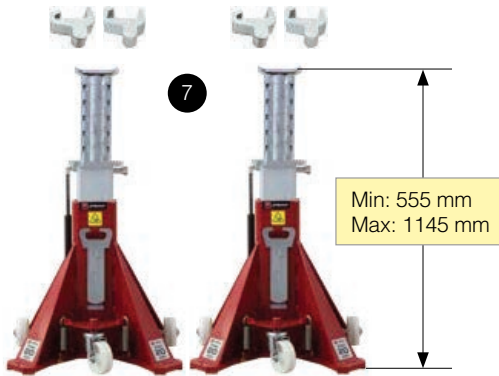

Table continues on next page
 Tabellen fortsätter på nästa sida
 Tabelle weiter auf der nächsten Seite





7	JO2480 A	15818	2	Vertical press 20 ton with cylinder and frame-flange press heads	Vertikalpress 20 ton med cylinder och flänsstöd	Vertikalpresse 20 Tonnen mit Zylinder und Druckstücken
8	JO SA 3	15817	1	Straightening accessories basic set	Riktillbehör grundsats	Richten-Zubehör Grundausrüstung
9	SR 90 K	12587	1	Mounting display board, three sections	Upphängningstavla, tre sektioner	Montagewand, drei Sektionen
10	H1039	14953	1	Remote controlled, air driven hydraulic pump with 4 outlets and two 6 m extension hoses	Fjärrmanövrerad lufthydraulisk pump med 4 utgångar och två 6-meters förlängningsslangar	Ferngesteuerte, lufthydraulische Pumpe mit 4 Ausgänge und zwei Stück 6 m Schläuche





Frame press – Basic kit

Choose this set when frame straightening is to be performed part time in an all-round bay.

This straightening set covers the basic needs to correct a truck chassis. The set can of course be upgraded to increase efficiency and functionality to be able to also straighten trailers, cabs and buses.

The set consists of:

- **Three 20 ton counterstay trolleys** with standard brackets, all in high strength aluminum, used together with a **20-ton hydraulic kit** to perform side sway correction.
- **Two vertical presses** that together with the anchoring kit enable you to correct vertical bends and chassis twist.
- **Two C-clamp kits** (20 and 10 ton) as well as **two hydraulic kits** (20 and 10 ton), which are used to correct local deformations.
- **Two foot controlled hydraulic pumps**, to maneuver multiple hydraulic units at the same time.

For options and accessories, see pages 19–28.





JO FP BASIC K/15908

Basic frame straightening kit excluding floor beams

Enklare ramriktssats exklusive golvspår

Einfachere Rahmenrihtsatz exklusive Fundamentrahmen



Basic kit

#	Article #	Order #	Pcs.	EN	SE	DE
1	JO 21 AL	11116	3	Counterstay trolley 20 ton aluminium	Mothållsbrygga 20 ton aluminium	Gegenbrücke 20 Tonnen Aluminium
2	JO HA 20	15076	1	20 ton hydraulic kit	20 ton hydrauliktillbehörssats	20 Tonnen Zubehörssatz Hydraulik



Table continues on next page
Tabellen fortsätter på nästa sida
Tabelle weiter auf der nächsten Seite

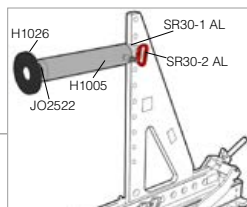
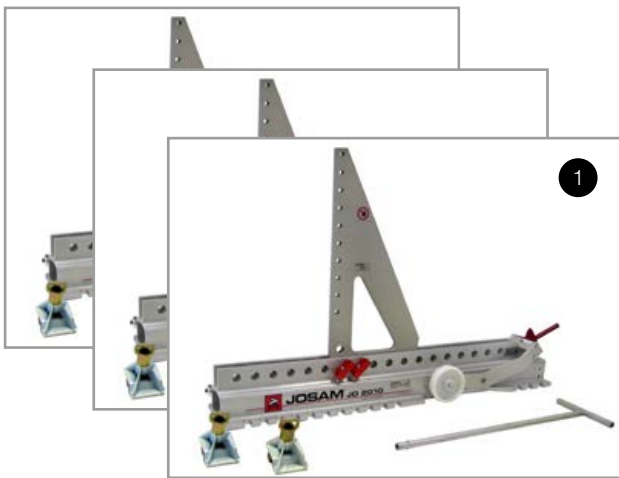

The JOSAM frame press is anchored to a frame rack in the floor.

These rails are not included, but drawings for local construction are provided.

JOSAM frame press förankras i golvspår ingjutna i verkstadsgolvet.

Dessa golvspår ingår ej, men ritningar för lokal konstruktion finns tillgängliga.

Die JOSAM-Rahmenrichtanlage ist an einem Fundamentrahmen im Boden verankert. Diese Schienen sind nicht enthalten, aber Zeichnungen für den lokalen Aufbau werden zur Verfügung gestellt.



3	JO HA 10	15077	1	10 ton hydraulic kit	10 ton hydraulikillbehörssats	10 Tonnen Zubehörsatz Hydraulik
4	JO 1320 K	12590	1	20 ton C-clamp set	20 ton riktbygelsats	20 Tonnen Richtbügelsatz
5	SR 31 K	12588	1	10 ton C-clamp set	10 ton riktbygelsats	10 Tonnen Richtbügelsatz

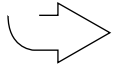
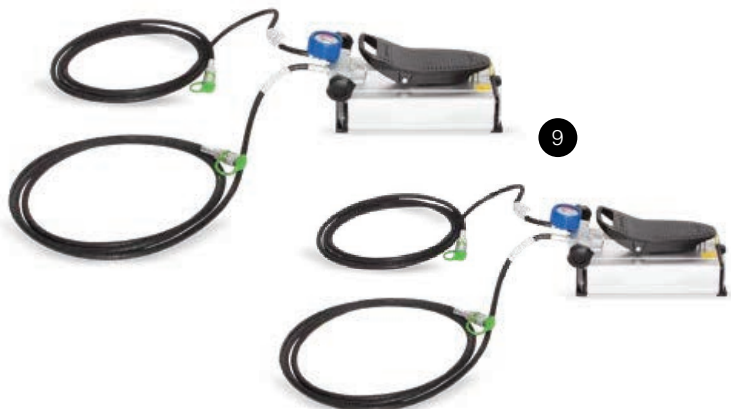
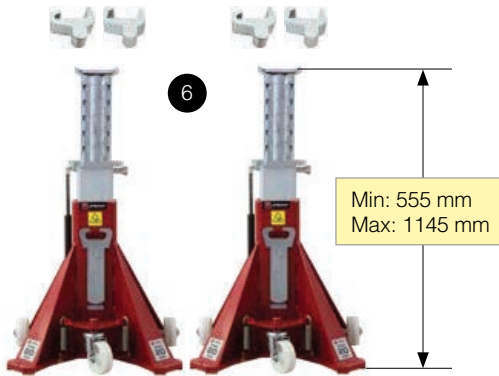

Table continues on next page
 Tabellen fortsätter på nästa sida
 Tabelle weiter auf der nächsten Seite





6	JO2480 A	15818	2	Vertical press 20 ton with cylinder and frame-flange press heads	Vertikalpress 20 ton med cylinder och flänsstöd	Vertikalpresse 20 Tonnen mit Zylinder und Druckstücken
7	JO SA 3	15817	1	Straightening accessories basic set	Riktillbehör grundsats	Richten-Zubehör Grundausrüstung
8	SR 90 K	12587	1	Mounting display board, three sections	Upphängningstavla, tre sektioner	Montagewand, drei Sektionen
9	H1053	16544	2	Foot controlled hydraulic pump with two 4 m hoses	Fotdriven hydraulisk pump med två 4-meters slangar	Fußgeregelt, lufthydraulische Pumpe mit zwei 4 m Schläuche





JOSAM frame press – options

For frame straightening it is highly recommended to use heat to release strain and tension in the frame components. The best tool for this is the JOSAM induction heater, allowing you to concentrate the heat into the required area instead of a gas flame heating a big area.

To increase your efficiency and flexibility, a set of trailer tools, a high reach pulling tower and a storage solution can be added.

For documentation of the frame errors as well as guide during straightening, a laser based frame measuring kit is available. This can be upgraded to a camera based wheel alignment system to make a perfect job by aligning the wheels and axles before the truck is returned to the customer.





JO FP TRAILER K/15913

Straightening set for trailers

Riktsats för trailers

Richtsatz für Auflieger



#	Article #	Order #	Pcs.	EN	SE	DE
1	JO 2130 K	11117	1	Frame hook set for semitrailers	Ramhakesats för semitrailer	Rahmenhakensatz für Sattelaufleger
2	JO248003-2	11618	1	Extension tube	Förlängningstub	Verlängerungsteil
3	JO2475	11610	2	Adjustable frame flange press head for trailers	Justerbart flänsstöd för trailers	Druckstück für Rahmenflanken, justierbar für Auflieger
4	JO 2030 K	11115	1	Frame hook set for i-beam	Ramhakesats för i-balk	Rahmenhakensatz für I-Strebe

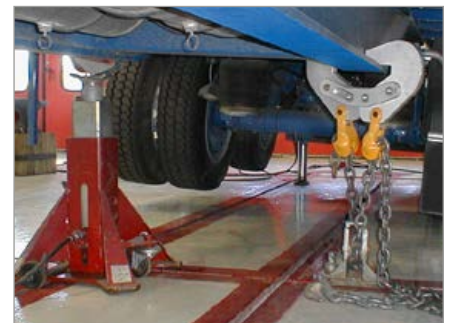
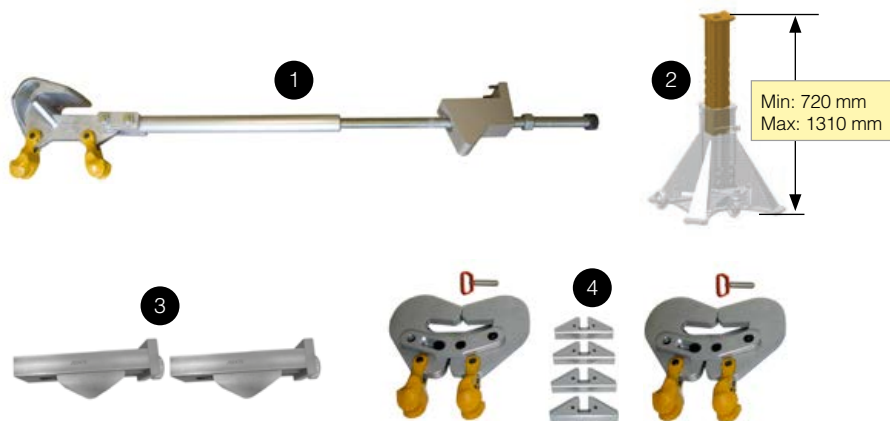



JH 1000-400 K/14811, JH1000-200 K/14812

Induction heater JH1000

Induktionsvärmare JH1000

Induktionserhitzer JH1000

#	Article #	Order #	Pcs.	EN	SE	DE
1	JH 1000-400 K	14811	1	Induction heater complete, 10 kW, 380-400 V	Induktionsvärmare komplett, 10 kW, 380-400 V	Induktionserhitzer komplett, 10 kW, 380-400 V
2	JH 1000-200 K	14812	1	Induction heater complete, 10 kW, 200-240 V	Induktionsvärmare komplett, 10 kW, 200-240 V	Induktionserhitzer komplett, 10 kW, 200-240 V

1 2



JH 1500-400 K, JH1500-200 K/15079, 15358

Induction heater JH1500

Induktionsvärmare JH1500

Induktionserhitzer JH1500

#	Article #	Order #	Pcs.	EN	SE	DE
1	JH 1500-400 K	15079	1	Induction heater complete, 13 kW, 380-400 V	Induktionsvärmare komplett, 13 kW, 380-400 V	Induktionserhitzer komplett, 13 kW, 380-400 V
2	JH 1500-200 K	15358	1	Induction heater complete, 13 kW, 200 V	Induktionsvärmare komplett, 13 kW, 200 V	Induktionserhitzer komplett, 13 kW, 200 V

1 2

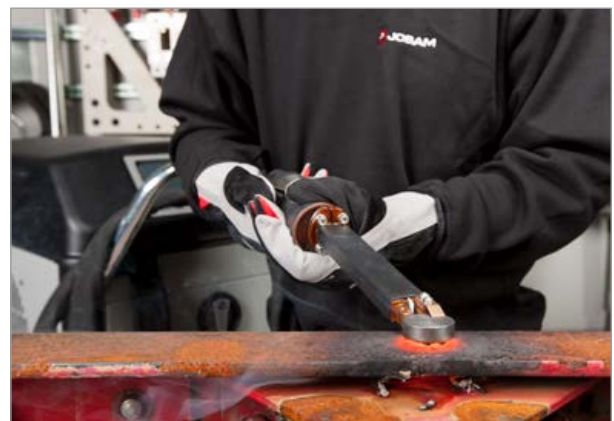



F 3 D/13552

Frame measurement kit

Rammätsats

Rahmenvermessungsatz

#	Article #	Order #	Pcs.	EN	SE	DE
1	F 3 D	13552	1	Frame measurement kit	Rammätsats	Rahmenvermessungsatz





ES50032/16526

Basic storage module, trolley

Grundmodul förvaring, vagn

Grundmodul Lagerung, Wagen

#	Article #	Order #	Pcs.	EN	SE	DE
1	ES50032	16526	1	Basic storage module, trolley	Grundmodul förvaring, vagn	Grundmodul Lagerung, Wagen

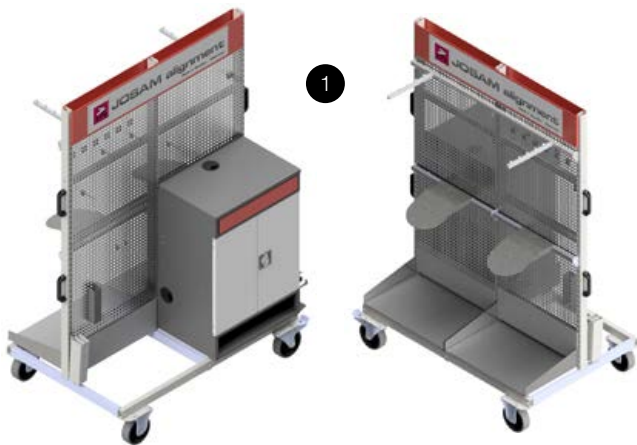

Choose add-on storage on the following page.

Välj tilläggsförvaring på följande sida.

Wählen Sie bitte Zusatz-Lagerung an folgende Seite.

ES50033/16527

Basic storage module, wall

Grundmodul förvaring, vägg

Grundmodul Lagerung, Wand

#	Article #	Order #	Pcs.	EN	SE	DE
1	ES50033	16527	1	Basic storage module, wall	Grundmodul förvaring, vägg	Grundmodul Lagerung, Wand

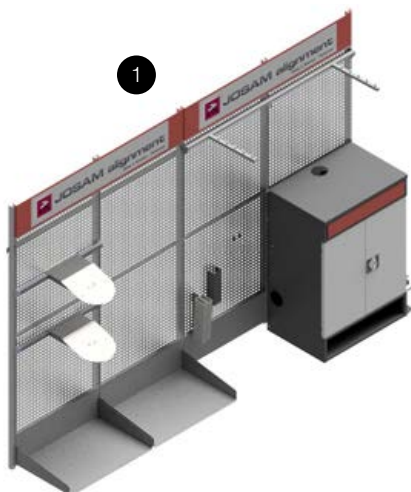

Choose add-on storage on the following page.

Välj tilläggsförvaring på följande sida.

Wählen Sie bitte Zusatz-Lagerung an folgende Seite.



ES551/14721

JOSAM laser AM add-on

JOSAM laser AM tilläggsats

JOSAM laser AM Zusatzgerät

#	Article #	Order #	Pcs.	EN	SE	DE
1	ES551	14721	1	Laser AM add-on	Laser AM tilläggsats	Laser AM Zusatzgerät

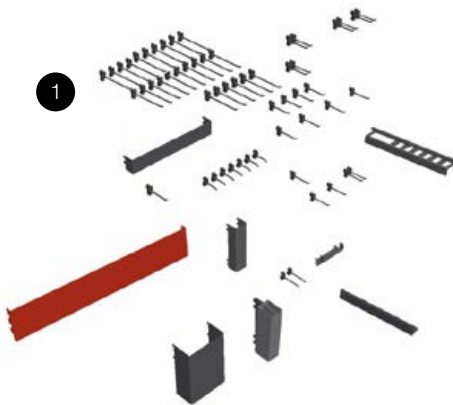

CA 2015 K/75050

JOSAM cam-aligner upgrade kit for F 3 D

JOSAM cam-aligner uppgraderingssats för F 3 D

JOSAM cam-aligner Upgrade Kit für F 3 D



Upgrade from
F 3 D

#	Article #	Order #	Pcs.	EN	SE	DE
1	CA 2011 K	74320	1	JOSAM cam-aligner upgrade kit for JOSAM laser AM	JOSAM cam-aligner uppgraderingssats för JOSAM laser AM	JOSAM cam-aligner Upgrade Kit für JOSAM laser AM
2	AM10 B	14303	1	Wheel adapter universal 16-24"	Hjuladapter universal 16"-24"	Radhalter universal 16"-24"
3	AM268 A	13762	2	Non friction plate	Antifriktionsplatta	Antifriktionsplatte





JO HIGH PULL/15912

High pulling additional kit for i-beams in floor

Höga drag tilläggsats för i-balk i golv

Höhe ziehen Ergänzungssatz für Fundamentrahmen im Boden



#	Article #	Order #	Pcs.	EN	SE	DE
1	JO 3200 AL	15673	1	Pulling tower for I-beam floor	Dragtorn för I-balksgolv	Ziehturm für Fundamentrahmen
2	JO HRS 10	11155	1	Accessories for cab straightening 10 ton (I-beam floor)	Tillbehörssats för hyttriktning 10 ton (I-balksgolv)	Zubehör für Kabinenrichten 10 Tonnen (Fundamentrahmen)

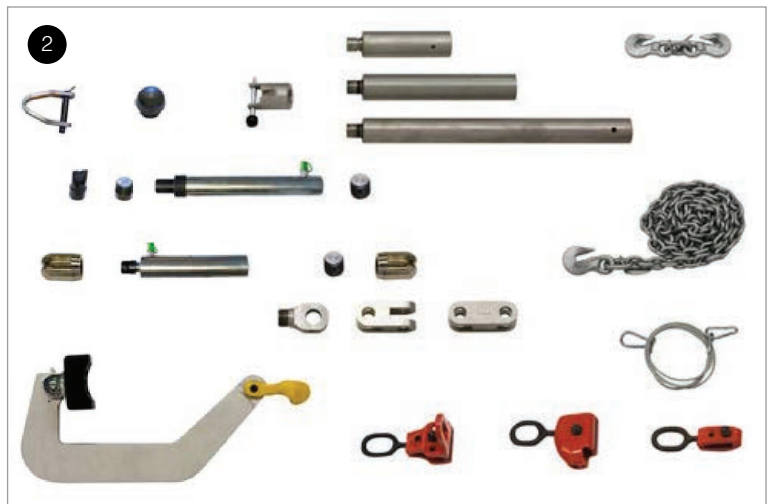



JOSAM frame press – accessories





Recommended accessories (15984)

Rekommenderade tillbehör

Empfohlenes Zubehör

#	Article #	Order #	Pcs.	EN	SE	DE
1	JO2105-1	11446	2	Frame flange press head 145-205 mm	Flänsstöd 145-205 mm	Druckstück Rahmenflanken 145-205 mm
2	JO2105-2	11447	2	Frame flange press head 195-305 mm	Flänsstöd 195-305 mm	Druckstück Rahmenflanken 195-305 mm
3	SR 29 K	13495	1	10 ton C-clamp set with flat nose C-clamp	10 ton riktbygelsats med plattnosbygel	10 Tonnen Richtbügelsatz mit Bügel flachen Gegenlager
4	JO 1289 K	13496	1	10 ton C-clamp set with short flat nose C-clamp	10 ton riktbygelsats med kort plattnosbygel	10 Tonnen Richtbügelsatz mit kurz Bügel flachen Gegenlager
5	SR 31 K	12588	1	10 ton C-clamp set	10 ton riktbygelsats	10 Tonnen Richtbügelsatz
6	JO 1320 K	12590	1	20 ton C-clamp set	20 ton riktbygelsats	20 Tonnen Richtbügelsatz
7	SR 450 N R	12585	1	C-clamp press 40 ton, complete	Nitbygelsats, 40 ton komplett	Nietbügelsatz, 40 Tonnen, kompl.
8	JO 1876 K	11108	1	20 ton straightening set frame	20 ton riktsats för ramfläns	20 Tonnen Richtsatz Rahmenflansch
9	JO TD 30	11167	1	Anchoring set 30 ton	Förankringsatts 30 ton	Verankerungsatts 30 Tonnen
10	JO TD 30 OPT	11168	1	Chain 20 ton 3 m with one pulley wheel	Kätting 20 ton 3 m med en brytrulle	Kette 20 Tonnen 3 m mit einer Umlenkrolle
11	H1053	16544	1	Foot controlled hydraulic pump with two 4 m hoses – two exits	Fotdriven hydraulisk pump med två 4 m slang – två utgångar	Fußgeregelt, lufthydraulische Pumpe mit zwei Stück 4 m Schlauch – zwei Ausgänge

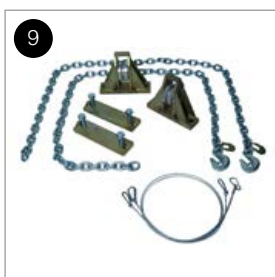
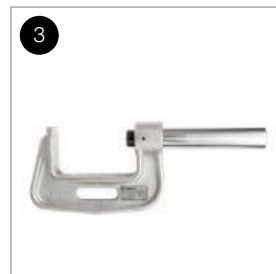



12	H1039	14953	1	Remote controlled, air driven hydraulic pump with 4 outlets and two 6 m extension hoses	Fjärrmanövrerad lufthydraulisk pump med 4 utgångar och två 6-meters förlängningsslangar	Ferngesteuerte, lufthydraulische Pumpe mit 4 Ausgänge und zwei Stück 6 m Schläuche
13	JO1175	11246	1	Pit trolley for 1000 mm pit, INP200	Gropvagn för 1000 mm grop, INP200	Grubenwagen für 1000 mm Grube, INP200
14	JO1175-1200	11247	1	Pit trolley 1200 mm, INP200	Gropvagn 1200 mm, INP200	Grubenwagen 1200 mm, INP200
15	JO587	15439	1	Pit trolley 1000 mm, IPE240	Gropvagn 1000 mm, IPE240	Grubenwagen 1000 mm, IPE240
16	JO 1175 OPT	11100	1	Lifting set for pit trolley	Lyftsats för gropvagn	Hebesatz für Grubenwagen
17	JO 2130 K	11117	1	Frame hook set for semitrailers	Ramhakesats för semitrailer	Rahmenhakensatz für Sattelaufleger
18	JO2475	11610	2	Adjustable frame flange press head for trailers	Justerbart flänsstöd för trailers	Druckstück für Rahmenflanken, justierbar für Auflieger
19	JO850	11702	1	Jacking stand 10 ton	Pallbock 10 ton	Stützbock 10 Tonnen
20	JO2480 A	15818	1	Vertical press 20 ton with cylinder and frame-flange press heads	Vertikalpress 20 ton med cylinder och flänsstöd	Vertikalpresse 20 Tonnen mit Zylinder und Druckstücken
21	JO248003-2	11618	1	Extension tube	Förlängningstüb	Verlängerungsteil
22	SR74 A	15819	1	Vertical press 20 ton without cylinder, with frame-flange press heads	Vertikalpress 20 ton utan cylinder, med flänsstöd	Vertikalpresse 20 Tonnen ohne Zylinder, mit Druckstücken
23	BL 3 TK	10728	1	JOSAM drill complete set	JOSAM bormaskin komplett sats	JOSAM Bohrmaschine komplett Satz
24	BL 3 TB	10727	1	JOSAM drill BL3, lever and chain	JOSAM bormaskin BL3, hävarm och kedja	JOSAM Bohrmaschine BL3, Hebel und Kette
25	JO1705	11340	1	Thread protection for cylinder 10 ton	Gängskydd för cylinder 10 ton	Gewindeschutz Zylinder 10 Tonnen
26	JO1713	11344	1	Thread protection for cylinder 20 ton	Gängskydd för cylinder 20 ton	Gewindeschutz Zylinder 20 Tonnen

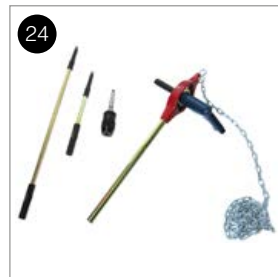
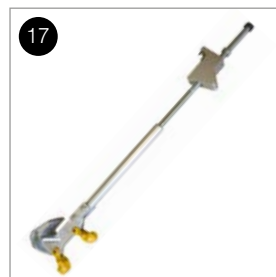



JOSAM i-press – Advanced kit

Choose this set to install frame straightening in a workshop with no frame beams installed.

This straightening set covers the normal needs to correct a truck chassis. The set can of course be complemented with a high reach pulling tower to be able to also straighten cabs and buses.

The set consists of:

- **Three 10 ton press trolleys** in high strength aluminum to perform side sway correction. This allows for both press and pull operations to perform side sway correction.
- **Two flex foot kits** that together with the anchoring kit, which enable you to correct vertical bends and chassis twist.
- **Two C-clamp kits** (40 and 10 ton) as well as **two hydraulic kits** (20 and 10 ton), which are used to correct local deformations.
- **Two foot controlled hydraulic pumps**, to maneuver multiple hydraulic units at the same time.

For options and accessories, see pages 36–43.





JO IP ADVANCED K/15911

Basic straightening kit including 9.6 m centre beam

Enklare ramriktssats inklusive 9,6 m centrumbalk

Einfachere Rahmenrichtsatz inklusive 9,6 m Hauptträger



Advanced kit

#	Article #	Order #	Pcs.	EN	SE	DE
1	JO 3001	12896	3	Straightening unit 10 ton	Riktenhet 10 ton	Richteinheit 10 Tonnen
2	JO 3002	12897	1	Equipment for vertical press 10 ton	Riktutrustning för vertikalpress 10 ton	Richtausrüstung für Vertikalpresse 10 Tonnen

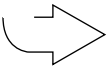
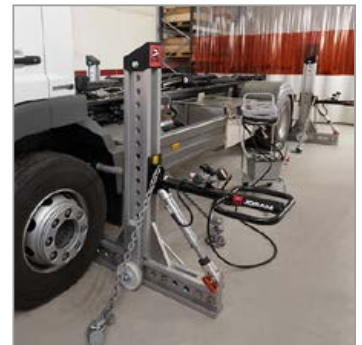
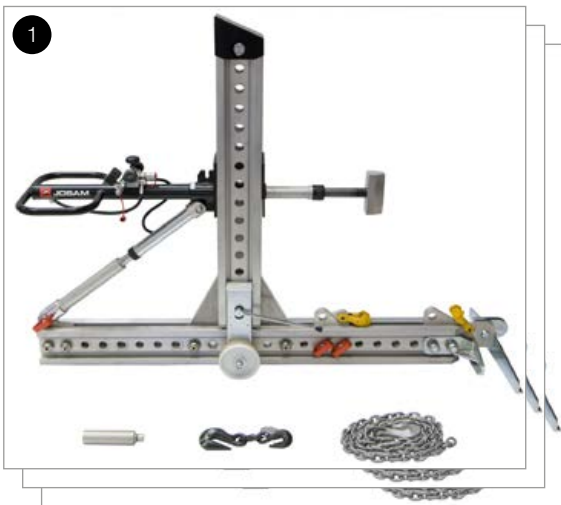

Table continues on next page
Tabellen fortsätter på nästa sida
Tabelle weiter auf der nächsten Seite





3	JO 3003	12900	1	Start kit for floor anchoring	Startutr. för golvförankring	Startausrustung für Bodenverankerung
4	JO 3004	12901	2	Complement kit for floor anchoring	Kompl.utr. för golvförankring	Kompl.ausrüstung für Bodenverankerung

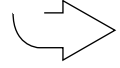
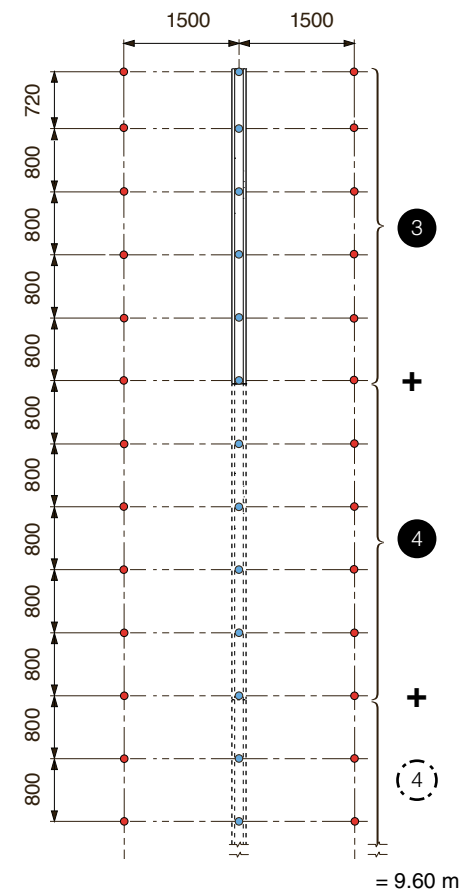
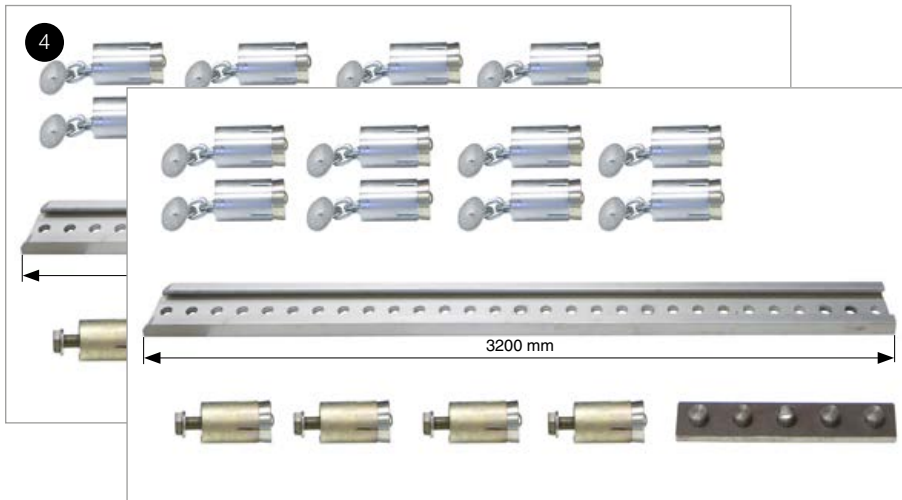
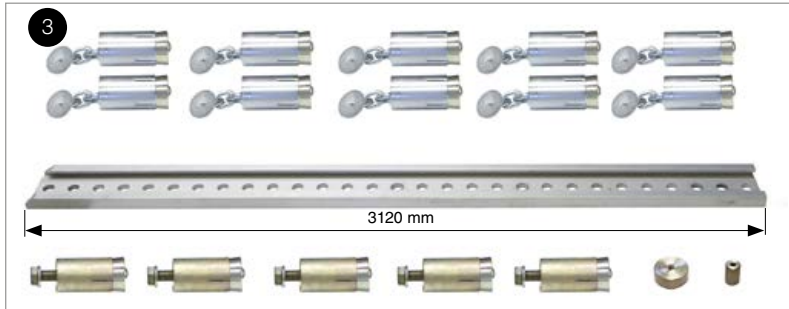

Table continues on next page
 Tabellen fortsätter på nästa sida
 Tabelle weiter auf der nächsten Seite



JOSAM i-press is anchored in a centre beam and floor anchorings that are included in the equipment. This kit covers a workplace of 9.6 x 3 m. It can easily be extended with sections of 3.2 m.

Core drill, fastening tool and drilling machine are not included in the kit.

JOSAM i-press förankras i en centrumskena samt i golvförankringar som ingår i utrustningen. Satsen täcker en arbetsplats om 9,6 m x 3 m. Den kan enkelt förlängas med sektioner om 3,2 m.

Borrkona, dragverktyg samt bormaskin ingår ej i satsen.

JOSAM i-press ist in einem Mittelbalken und Bohrtöpfen verankert, die in der Ausstattung enthalten sind. Dieser Bausatz umfasst einen Arbeitsplatz von 9,6 x 3 m. Er kann problemlos mit Abschnitten von 3,2 m verlängert werden.

Kernbohrer, Befestigungswerkzeug und Bohrmaschine sind nicht im Lieferumfang enthalten.



5	JO 3005	12902	1	Safety anchoring for vehicle	Säkerhetsförankring för fordon	Sicherheitsverankerung für Fahrzeuge
6	JO300013	13027	2	Socket with shaft 46 mm	Hylsa med skaft 46 mm	Hülse mit Schaft 46 mm

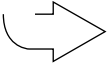
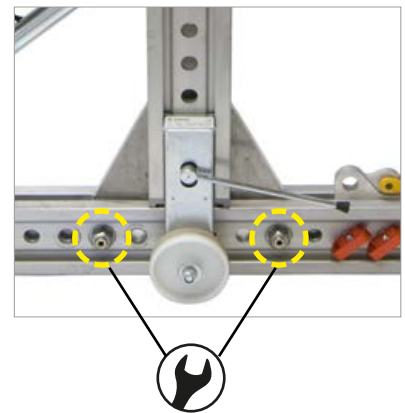
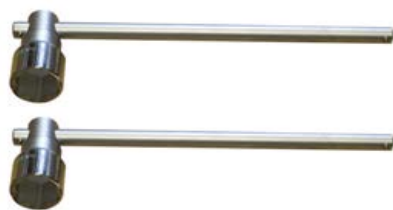

Table continues on next page
 Tabellen fortsätter på nästa sida
 Tabelle weiter auf der nächsten Seite

5



6





7	JO HA 10	15077	1	10 ton hydraulic kit	10 ton hydraulikillbehörssats	10 Tonnen Zubehörsatz Hydraulik
8	-	-	1	20 ton hydraulic kit	20 ton hydraulikillbehörssats	20 Tonnen Zubehörsatz Hydraulik

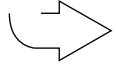
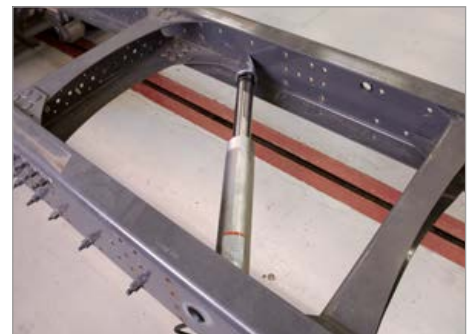

Table continues on next page
 Tabellen fortsätter på nästa sida
 Tabelle weiter auf der nächsten Seite





9	SR 450 N R	12585	1	40 ton C-clamp set for riveting and straightening	40 ton bygelsats för nitning och riktning	40 Tonnen Bügelsatz für Nieten und Richten
10	SR 31 K	12588	1	10 ton C-clamp set	10 ton riktbygelsats	10 Tonnen Richtbygelsatz

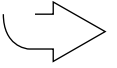

Table continues on next page
 Tabellen fortsätter på nästa sida
 Tabelle weiter auf der nächsten Seite





11	H1053	16544	2	Foot controlled hydraulic pump with two 4 m hoses	Fotdriven hydraulisk pump med två 4-meters slangar	Fußgeregelt, lufthydraulische Pumpe mit zwei 4 m Schläuche
12	JO2105-1	11446	2	Frame flange press head 145-205 mm	Flänsstöd 145-205 mm	Druckstück Rahmenflanken 145-205 mm
13	JO2105-2	11447	2	Frame flange press head 195-305 mm	Flänsstöd 195-305 mm	Druckstück Rahmenflanken 195-305 mm
14	SR 90 K	12587	1	Mounting display board, three sections	Upphängningstavla, tre sektioner	Montagewand, drei Sektionen





JOSAM i-press options

For frame straightening it is highly recommended to use heat to release strain and tension in the frame components. The best tool for this is the JOSAM induction heater, allowing you to concentrate the heat into the required area instead of a gas flame heating a big area.

To increase your efficiency and flexibility, a high reach pulling tower and a storage solution can be added.

For documentation of the frame errors as well as a guide during straightening, a laser based frame measuring kit is available. This can be upgraded to a camera based wheel alignment system to make a perfect job by aligning the wheels and axles before the truck is returned to the customer.



Induction heaters
See page 21



Frame measurement and storage
See pages 22-24



CT HIGH PULL/15914

High pulling additional kit with floor anchoring 7x9m

Höga drag tilläggsats med golvförankring 7x9m

Höhe Ziehen Ergänzungssatz mit Bohrtöpfen 7x9m



#	Article #	Order #	Pcs.	EN	SE	DE
1	CT 3200 AL	15635	1	Straightening kit - pulling	Riktsats - drag	Richtsatz - Ziehen
2	JO2324B AP K	14125	1	Floor anchoring kit for bus straightening	Golvförankringskit för bussrikt	Verankerungssatz für Busrichten





Work area for high pulling
 Område för höga drag
 Gebiet für höhe Ziehen

Work area for frame straightening
 Område för ramrikt
 Gebiet für Rahmenrichten

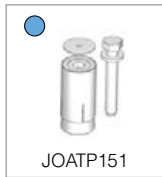

(mm)

16340

7000

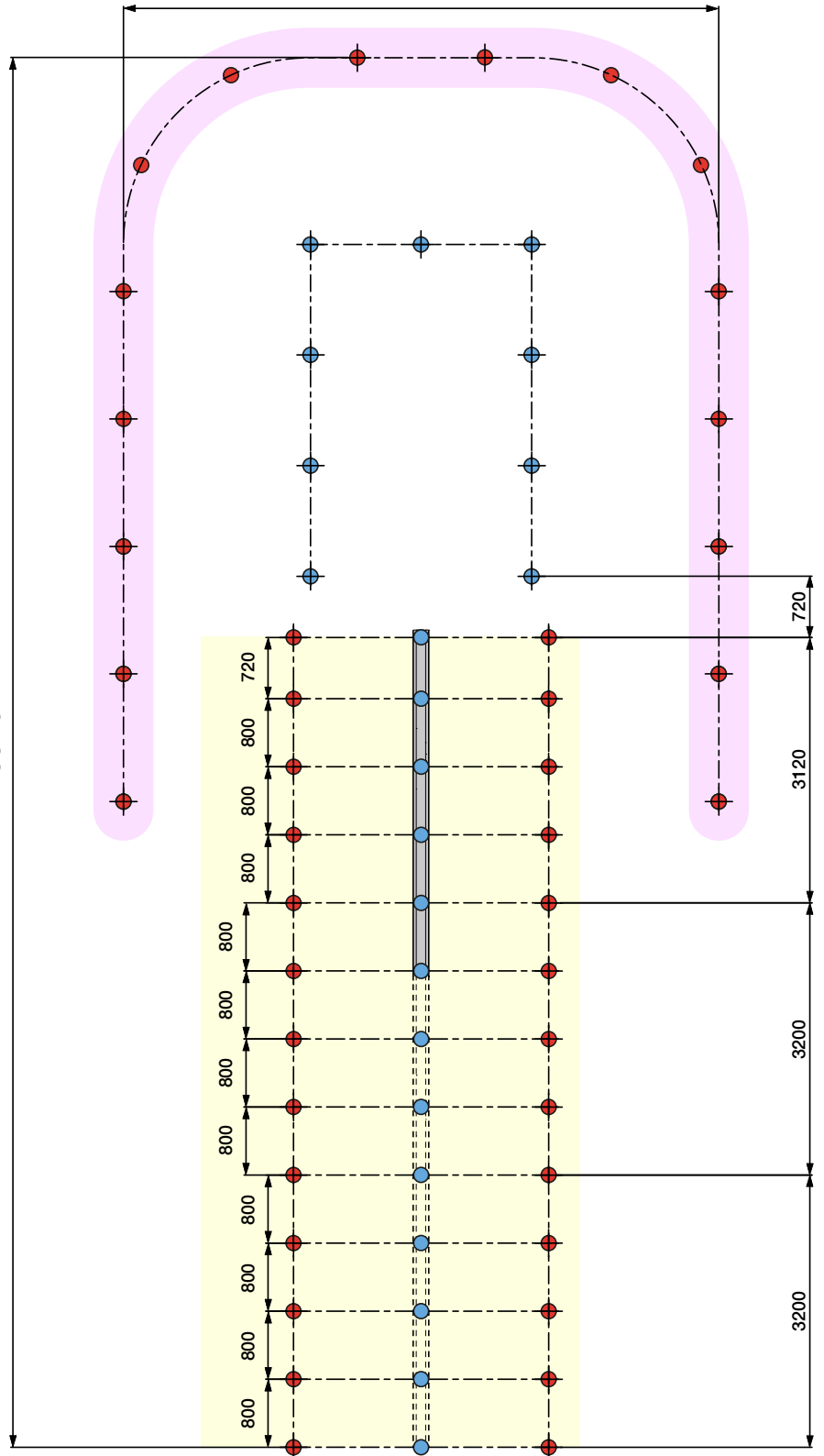

JOSAM i-press 9,6 meter in combination with high pulling function. The working place covers a total area of 16340 x 7000 mm.

JOSAM i-press 9,6 meter i combination med funktioner för höga drag. Arbetsplatsen täcker en yta om totalt 16340 x 7000 mm.

JOSAM i-press 9,6 Meter in Verbindung mit Funktionen für höhe Ziehen. Der Arbeitsplatz umfasst eine Gesamtfläche von 16340 x 7000 mm



3	CT 71	10786	1	Anchoring beam complete	Förankringsbalk komplett	Verankerungsstrebe komplett
4	CT 61 AL	10784	1	Straightening kit for vector pull and press	Riktsats för vektordrag och tryckfunktioner	Richtsatz für Vektorziehen und Pressen
5	CT 62 AL	10785	1	Additional kit for cab and bus straightening	Tilläggsats hytt- och bussrik	Ergänzungssatz Fahrerhaus- und Busrichten



The tower is not included in the set.
Tornet ingår ej i satsen.
Das Turm ist nicht im Satz enthalten.

Please note that **CT 71** is not a stock item and is only manufactured on request.
Notera att **CT 71** ej är lagervara och tillverkas endast mot beställning.
Bitte notieren Sie, dass **CT 71** keine Lagerware ist und nur nach Bestellung gefertigt wird.





Installation tools excluding drilling machine Installationsverktyg exklusive bormaskin Installationswerkzeuge ohne Bohrmaschine

#	Article #	Order #	Pcs.	EN	SE	DE
1	JO300011	13025	1	Core drill Ø 90 mm, thread TR28x3	Kärnborr Ø 90 mm, gänga TR28x3	Kernbohrer Ø 90 mm, Gewinde TR28x3
2	JOATP100	11719	1	Fastening tool for JOATP150	Fastsättningsverktyg för JOATP150	Befestigungswerkzeug für JOATP150



For the best result and the highest level of safety, always use JOSAM original core drill.

As for drilling machine we recommend a Hilti DD130 or likewise, with vacuum plate.

An adapter between the drilling machine and the core drill might be needed.

För bästa resultat och högsta säkerhet, använd alltid JOSAM original-kärnborr.

Som bormaskin rekommenderas Hilti DD130 eller liknande, med vakuumpatta.

Adapter mellan bormaskin och kärnborr kan behövas.

Für das beste Ergebnis und das höchste Maß an Sicherheit, verwenden Sie immer JOSAM Original Kernbohrer.

Als Bohrmaschine empfehlen wir eine Hilti DD130 oder gleichermaßen mit Vakuumpatte.

Ein Adapter zwischen der Bohrmaschine und dem Kernbohrer kann erforderlich sein.





JOSAM i-press accessories





Recommended accessories (15986)

Rekommenderade tillbehör

Empfohlenes Zubehör

#	Article #	Order #	Pcs.	EN	SE	DE
1	JO2105-1	11446	2	Frame flange press head 145-205 mm	Flänsstöd 145-205 mm	Druckstück Rahmenflanken 145-205 mm
2	JO2105-2	11447	2	Frame flange press head 195-305 mm	Flänsstöd 195-305 mm	Druckstück Rahmenflanken 195-305 mm
3	SR 29 K	13495	1	10 ton C-clamp set with flat nose C-clamp	10 ton riktbygelsats med plattnosbygel	10 Tonnen Richtbügelsatz mit Bügel flachen Gegenlager
4	JO 1289 K	13496	1	10 ton C-clamp set with short flat nose C-clamp	10 ton riktbygelsats med kort plattnosbygel	10 Tonnen Richtbügelsatz mit kurz Bügel flachen Gegenlager
5	SR 31 K	12588	1	10 ton C-clamp set	10 ton riktbygelsats	10 Tonnen Richtbügelsatz
6	JO 1320 K	12590	1	20 ton C-clamp set	20 ton riktbygelsats	20 Tonnen Richtbügelsatz
7	SR 450 N R	12585	1	C-clamp press 40 ton, complete	Nitbygelsats, 40 ton komplett	Nietbügelsatz, 40 Tonnen, kompl.
8	JO 1876 K	11108	1	20 ton straightening set frame	20 ton riktsets för ramfläns	20 Tonnen Richtsatz Rahmenflansch
9	KL13-10K	12304	1	Double hook 13-10 mm	Dubbelkrok 13-10 mm	Doppelhaken 13-10 mm
10	KL13-2K	12305	1	Double hook 13 mm	Dubbelkrok 13 mm	Doppelhaken 13 mm
11	H1053	16544	1	Foot controlled hydraulic pump with two 4 m hoses – two exits	Fotdriven hydraulisk pump med två 4 m slang – två utgångar	Fußgeregelt, lufthydraulische Pumpe mit zwei Stück 4 m Schlauch – zwei Ausgänge

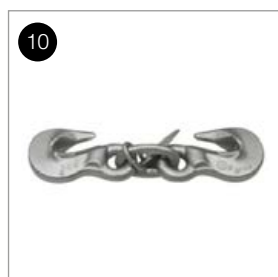
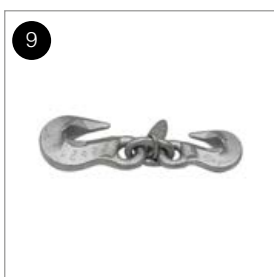
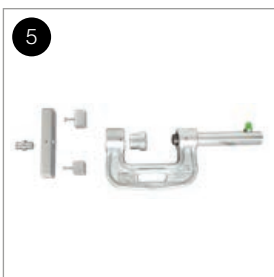
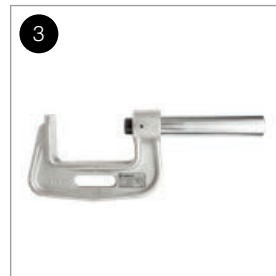



12	H1039	14953	1	Remote controlled, air driven hydraulic pump with 4 outlets and two 6 m extension hoses	Fjärrmanövrerad lufthydraulisk pump med 4 utgångar och två 6-meters förlängningsslangar	Ferngesteuerte, lufthydraulische Pumpe mit 4 Ausgänge und zwei Stück 6 m Schläuche
13	BL 3 TK	10728	1	JOSAM drill complete set	JOSAM bormaskin komplett sats	JOSAM Bohrmaschine komplett Satz
14	BL 3 TB	10727	1	JOSAM drill BL3, lever and chain	JOSAM bormaskin BL3, hävarm och kedja	JOSAM Bohrmaschine BL3, Hebel und Kette
15	JO1705	11340	1	Thread protection for cylinder 10 ton	Gängskydd för cylinder 10 ton	Gewindeschutz Zylinder 10 Tonnen
16	JO1713	11344	1	Thread protection for cylinder 20 ton	Gängskydd för cylinder 20 ton	Gewindeschutz Zylinder 20 Tonnen



We know that the product is never better than the support and training provided.

After 45 years in this business we have the absolute best support and training capability in the industry. This will secure that your investment in our equipment is sustainable.

JOSAM IS REPRESENTED
ALL OVER THE WORLD.
TO FIND YOUR NEAREST
DISTRIBUTOR, PLEASE
VISIT **WWW.JOSAM.SE**



REPRESENTATIVE:

MANUFACTURER:



Car-O-Liner Group AB • Box 419 • SE-701 48 Örebro • Sweden
Tel: +46 19 30 40 00 • E-mail: info@josam.se
Internet: www.josam.se

JOSAM© (2018) is a trademark of Snap-on Incorporated. All rights reserved.